

# DEMS 180

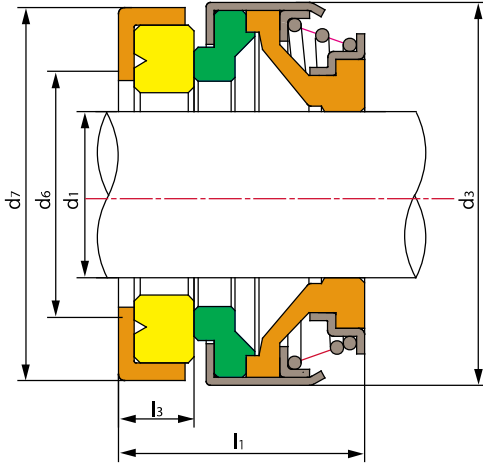

## Çalışma Limitleri

Basınç:  $\leq 0.6\text{MPa}$   
 Hız:  $\leq 10\text{m/s}$   
 Sıcaklık:  $-30^{\circ}\text{C} \sim +200^{\circ}\text{C}$

## Operating Limits

Pressure:  $\leq 0.6\text{MPa}$   
 Speed:  $\leq 10\text{m/s}$   
 Temperature:  $-30^{\circ}\text{C} \sim +200^{\circ}\text{C}$

18

- Döner Yüzey (Plastic Carbon/Carbon/SiC/TC)
- Sabit Eleman (Ceramic/SiC/TC)
- Elastomer (NBR/EPDM/VITON)
- Yay ve Diğer Parçalar (SUS304/SUS316)
- Rotary Ring(Plastic Carbon/Carbon/SiC/TC)
- Stationary Ring(Ceramic/SiC/TC)
- Secondary Seal(NBR/EPDM/VITON)
- Spring & Other Parts(SUS304/SUS316)

Model	d <sub>1</sub> (mm)	d <sub>3</sub>	d <sub>6</sub>	d <sub>7</sub>	l <sub>1</sub>	l <sub>3</sub>
DEMS 180-6	6	18	8	22.0	14.0	4.0
DEMS 180-8S	8	18	10	22.0	15.0	4.0
DEMS 180-8M	8	20	10	22/26	15/16.5	4.0/5.5
DEMS 180-8L	8	24	10	26.0	16.5	5.5
DEMS 180-10	10	24	12	26.0	21.0	8.0
DEMS 180-11	11	24	13	26.0	21.0	8.0
DEMS 180-12	12	24	14	25/26	21.0	8.0
DEMS 180-13	13	24	15	26.0	18.5/21	5.5/8.0
DEMS 180-13L	13	28	16	28.0	21.0	8.0
DEMS 180-13H	13	32	16	29.5	30.5	8.0
DEMS 180-14	14	28	16	28/28.5	21.0	8.0
DEMS 180-14L	14	32	16	29.5	21.0	8.0
DEMS 180-15S	15	28	16	28.5/30	21.0	8.0
DEMS 180-15M	15	32	16	30/29.5	21.0	8.0
DEMS 180-15L	15	39	18	38.0	21.0	8.0
DEMS 180-16S	16	28	16	29.5/30	21.0	8.0
DEMS 180-16M	16	32	18	29.5	21.0	8.0
DEMS 180-16L	16	39	18	38.0	21.0	8.0
DEMS 180-16H	16	32	16	30.0	29.0	10.0
DEMS 180-17	17	39	19	42.0	21.0	8.0
DEMS 180-18	18	39	20	42.0	21.0	8.0

Model	d <sub>1</sub> (mm)	d <sub>3</sub>	d <sub>6</sub>	d <sub>7</sub>	l <sub>1</sub>	l <sub>3</sub>
DEMS 180-19	19	39	21	42.0	21.0	8.0
DEMS 180-20	20	39	22	42.0	21.0	8.0
DEMS 180-20L	20	42	24	45.0	23.0	10.0
DEMS 180-22S	22	36	24	45.0	26.5	10.0
DEMS 180-22L	22	42	24	45.0	23.0	10.0
DEMS 180-23	23	47	25	50.0	23.5	10.0
DEMS 180-24	24	47	26	50.0	23.5	10.0
DEMS 180-25	25	42	27	50.0	23.5	10.0
DEMS 180-25L	25	47	27	50.0	23.5	10.0
DEMS 180-26	26	47	29	50.0	23.5	10.0
DEMS 180-27	27	47	30	50.0	23.5	10.0
DEMS 180-28	28	54	31	57.0	25.0	10.0
DEMS 180-30	30	54	33	57.0	25.0	10.0
DEMS 180-32	32	54	35	57.0	25.0	10.0
DEMS 180-35	35	60	38	63.0	26.0	10.0
DEMS 180-38	38	65	41	68.0	30.0	12.0
DEMS 180-40	40	65	43	68.0	30.0	12.0
DEMS 180-45	45	70	48	73.0	32.0	12.0
DEMS 180-50	50	85	52	88.0	38.0	15.0
DEMS 180-55	55	85	58	88.0	38.0	15.0
DEMS 180-60	60	105	63	110.0	45.0	15.0
DEMS 180-65	65	105	\	110.0	47.0	15.0
DEMS 180-70	70	105	\	110.0	47.0	15.0